



Case Study

Dedicado Builds IP Backbone Network with Ceragon Wireless Ethernet Solutions

Dedicado, a leading wireless Telecom Operator in Uruguay utilizes FibeAir® IP-MAX² combined with advanced port aggregation solution from a Ceragon strategic partner

Background

Dedicado Telecommunications is Uruguay's leading broadband wireless Telecom Operator. The company provides high-speed data access as well as telephony services to private and enterprise users and has its own network stretching over 2,000km across Uruguay.

In January 2009 Dedicado deployed a new wireless backbone solution based on Ceragon's FibeAir® IP-MAX² and a unique port aggregation solution from one of Ceragon's strategic partners.

The Challenge

Dedicado set out to construct a new 445 km (276 miles) backbone network to support the company's service expansion in Uruguay. In order to increase its network's cost-efficiency, Dedicado took a strategic decision to move away from TDM and focus on an all-IP architecture.

The new network also included a 50 km link over the Río de la Plata to connect to the international submarine communication cable landing across the Argentinean border. This huge waterway dictated the use of a robust radio solution, capable of successfully handling Multipath Fading and maintaining high capacity/high quality transmission of data.

Wireless IP Solutions for Fast and Reliable Backhaul Networks

Ceragon's IP/Ethernet radio was designed to provide maximum availability for backbone wireless networks. Featuring embedded space diversity, full adaptive coding and modulation (ACM) and ultra high power transmission, Ceragon solutions can greatly improve hop length, system performance and availability over any terrain and under varying weather conditions.

Dedicado selected a unique combination of Ceragon's FibeAir IP-MAX² and an advanced port aggregation solution from one of Ceragon's strategic partners. The combined solution allows for the aggregation of multiple physical Fast Ethernet and Gigabit Ethernet links into one logical Ethernet channel. This enables Dedicado to provide fault-tolerance and high-speed links between switches/routers. Additional benefits included: load sharing of traffic among the wireless Ethernet links in the channel and redundancy in the event that one or more links in the channel fails.

The features listed above give the combined microwave and port aggregation solution unmatched scalability and reliability that are ideal for high-quality transport of services, applications and cross-country digital broadcast connectivity.



“Ceragon's wireless Ethernet solutions combined with port aggregation technology represents an economical alternative to fiber optic lines and offers us a highly reliable ultra-long point-to-point transmission” (Eng. Fabian Buratti, Operations Manager, Dedicado)

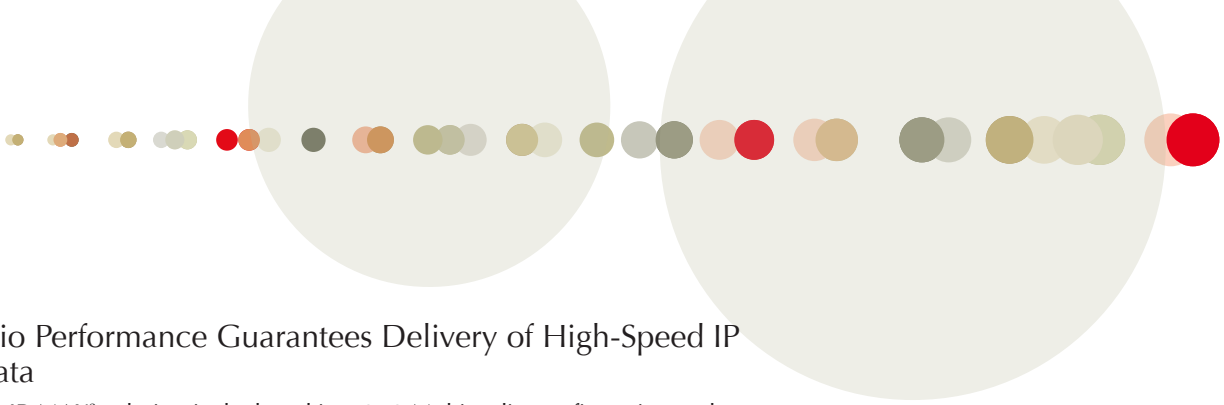

Superior Radio Performance Guarantees Delivery of High-Speed IP Voice and Data

Ceragon's FibeAir IP-MAX² solution is deployed in a 3+0 Multi-radio configuration at the first step, and later will be up-graded to 6+0, with a total availability superior to 99,999%. With FibeAir IP-MAX², each individual Ethernet frame is divided between the 3 and then 6 carriers. The system ensures high quality traffic delivery even during link fading conditions using Ceragon's advanced ACM mechanism. Once the modulation of any given radio carrier is reduced, the split ratio is adapted based on the ratio of the available capacity in each of the remaining carriers. Thus optimal utilization of the over-all link capacity is ensured.

FibeAir IP-MAX² supports flow-control frames to deal with network congestion. Thus, when congestion builds in the queues towards the radio interface, the solution does not drop any of the Ethernet frames. Congestion management is done by the connected switch/router at both edges of the network.



FibeAir IP-MAX², Carrier Ethernet Wireless Solution

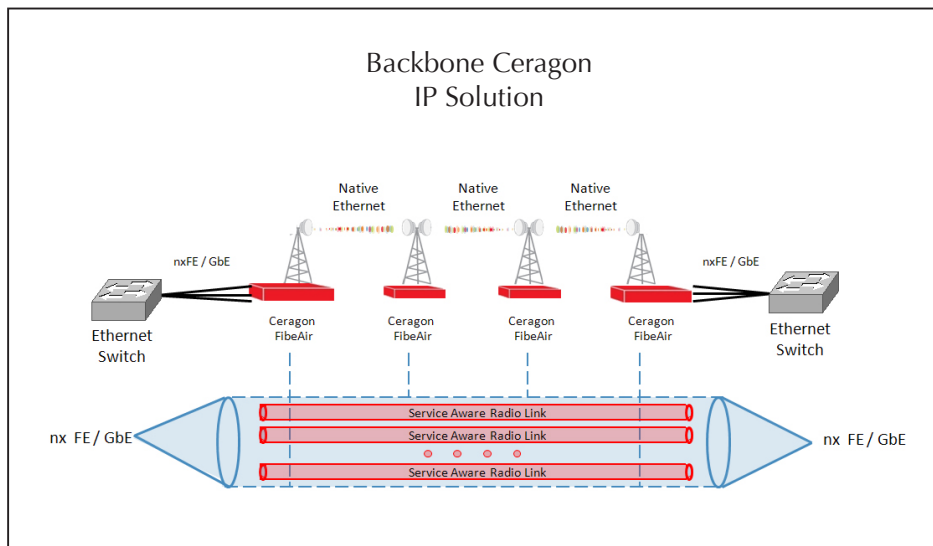

“Ceragon’s wireless Ethernet solutions combined with port aggregation technology represents an economical alternative to fiber optic lines and offers us a highly reliable ultra-long point-to-point transmission,” said Eng. Fabian Buratti, Operations Manager, Dedicado. “We were particularly impressed by Ceragon’s Adaptive Coding and Modulation technology and the fact that we were able to bridge over a wide body of water without compromising on quality or availability.”

About Ceragon

Ceragon Networks Ltd. (NASDAQ: CRNT) is a leading provider of high capacity wireless backhaul solutions that enable fiber-like connectivity for SONET/SDH networks, next generation IP-based networks and hybrid networks. Ceragon's FibeAir® family of products support all wired and wireless access technologies and address Service Providers' need to cost-effectively build-out and scale their networks to meet increasing demands for bandwidth and premium services. Ceragon's solutions are deployed by more than 230 service providers of all sizes, and hundreds of private networks in more than 130 countries. More information is available at www.ceragon.com.

Ceragon Networks®, CeraView®, FibeAir® and the FibeAir® design mark are registered trademarks of Ceragon Networks Ltd., and Ceragon™, PolyView™, ConfigAir™, CeraMon™, EtherAir™, QuickAir™, QuickAir Partner Program™, QuickAir Partner Certification Program™, QuickAir Partner Zone™, EncryptAir™ and Microwave Fiber™ are trademarks of Ceragon Networks Ltd. All rights reserved

